

Harmsco® Filtration Products

Installation Diagram

Hurricane® 8XBAG SB Swing Bolt Housing

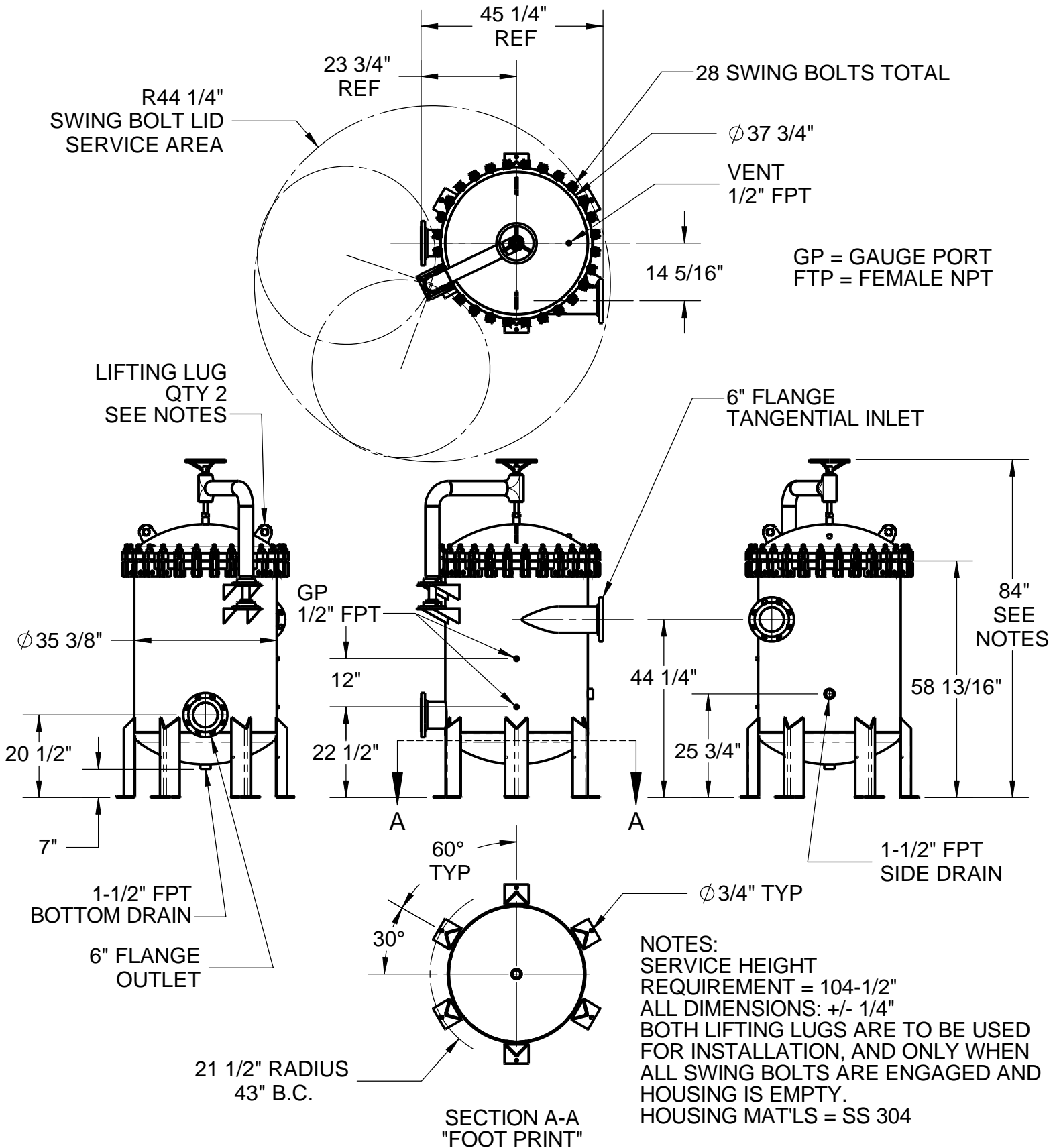

NOTES:
 SERVICE HEIGHT REQUIREMENT = 104-1/2"
 ALL DIMENSIONS: +/- 1/4"
 BOTH LIFTING LUGS ARE TO BE USED FOR INSTALLATION, AND ONLY WHEN ALL SWING BOLTS ARE ENGAGED AND HOUSING IS EMPTY.
 HOUSING MAT'LS = SS 304

MODEL #: HUR 8XBAG SB